

# **ESRO-2 and HEOS-1**

Europe's pioneers for the study  
of the dynamics of the Earth's  
space environment

André Balogh

Imperial College London, and  
International Space Science Institute, Bern

With thanks to Arthur Bewick, Andrew Engel, Doug Millard and Brian Taylor

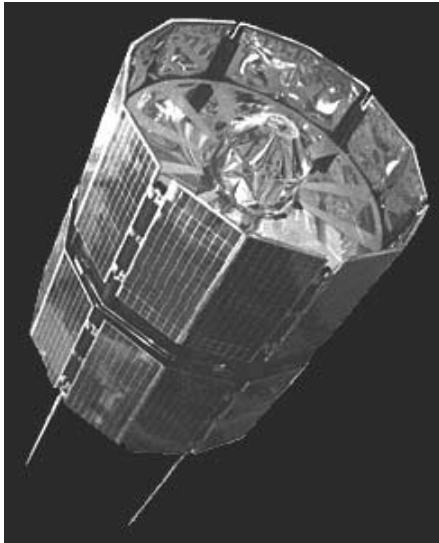

## ESRO-2 (launched 16 May 1968)

The objective of Europe's first space weather mission was to understand the effects of energetic solar events in the Earth's environment

### ESRO-2 PAYLOAD

Experiment	Title	Group	Group leader
S-25	Monitor of energetic particle flux	Imperial College, London	Prof. H. Elliot
S-27	Solar and Van Allen belt protons	Imperial College, London	Prof. H. Elliot
S-28	Solar and galactic $\alpha$ -particles and protons	Imperial College, London	Prof. H. Elliot
S-29	Primary cosmic ray electrons	University of Leeds	Dr. P. Marsden
S-36	Hard solar X-rays	University College, London	Prof. R. L. F. Boyd
S-37	Soft solar X-rays	Laboratorium voor Ruimte-Onderzoek, Utrecht	Prof. C. de Jager
S-72	Flux and energy spectrum of solar and galactic particles	C.E.N.S., France	Prof. J. Labeyrie

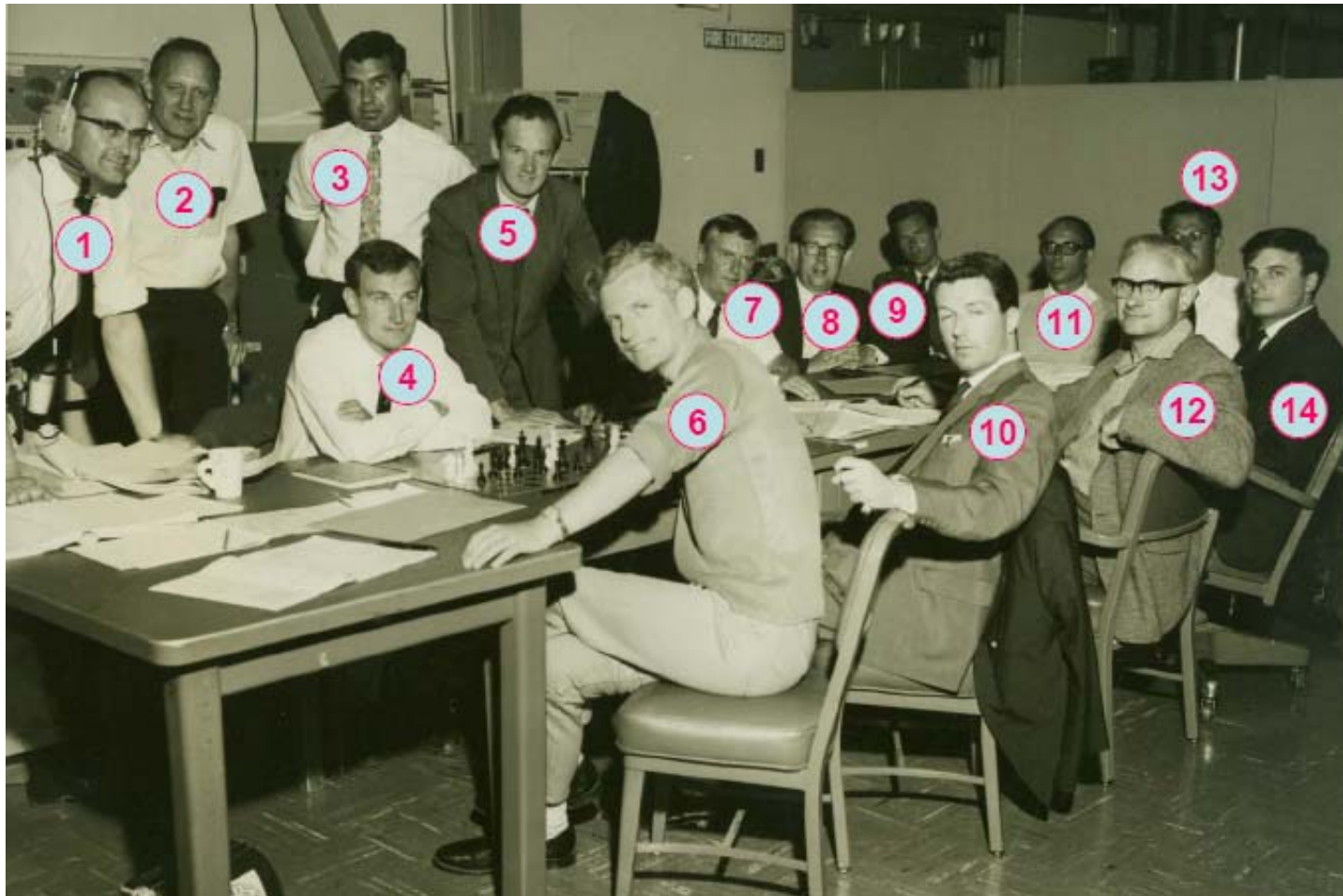

## ESRO-2 SCIENCE TEAM

1	Chris Bryant (Hawker Siddely Dynamics)		8	Phil Marsden (University of Leeds)	S29
2	NASA representative		9	Bob Hynds (Imperial College London)	S27
3	Mike Shaw (University College London)	S36	10	Edgar Page (ESRO)	
4	A. Brinkman (University of Utrecht)	S37	11	Hans Imhof (University of Utrecht)	S37
5	Barry Crowden (University of Leeds)	S29	12	R.L.F.Boyd (University College London)	S36
6	Alastair Durney (Imperial College London)	S28	13	Yves Amran (Saclay)	S72
7	Jacques Andrejol (Saclay)	S72	14	Arthur Bewick (Imperial College London)	S25

Three instruments  
to measure  
energetic particles  
in the  
magnetosphere in  
response to solar  
storms

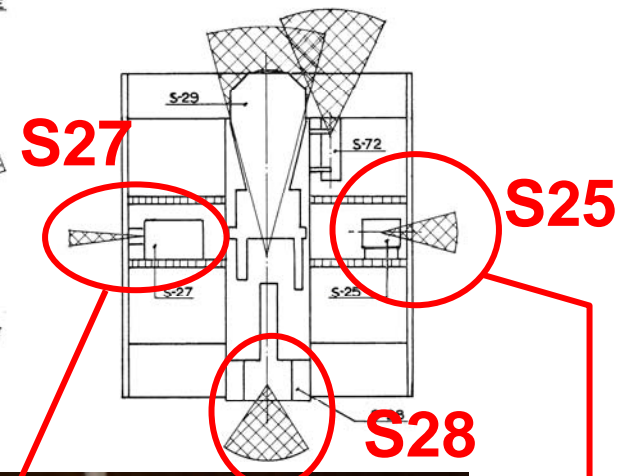
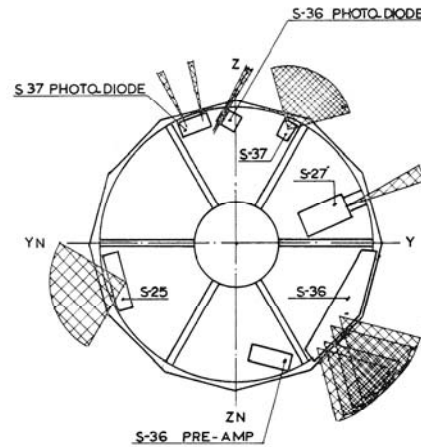

# High-energy protons access the Earth's polar regions

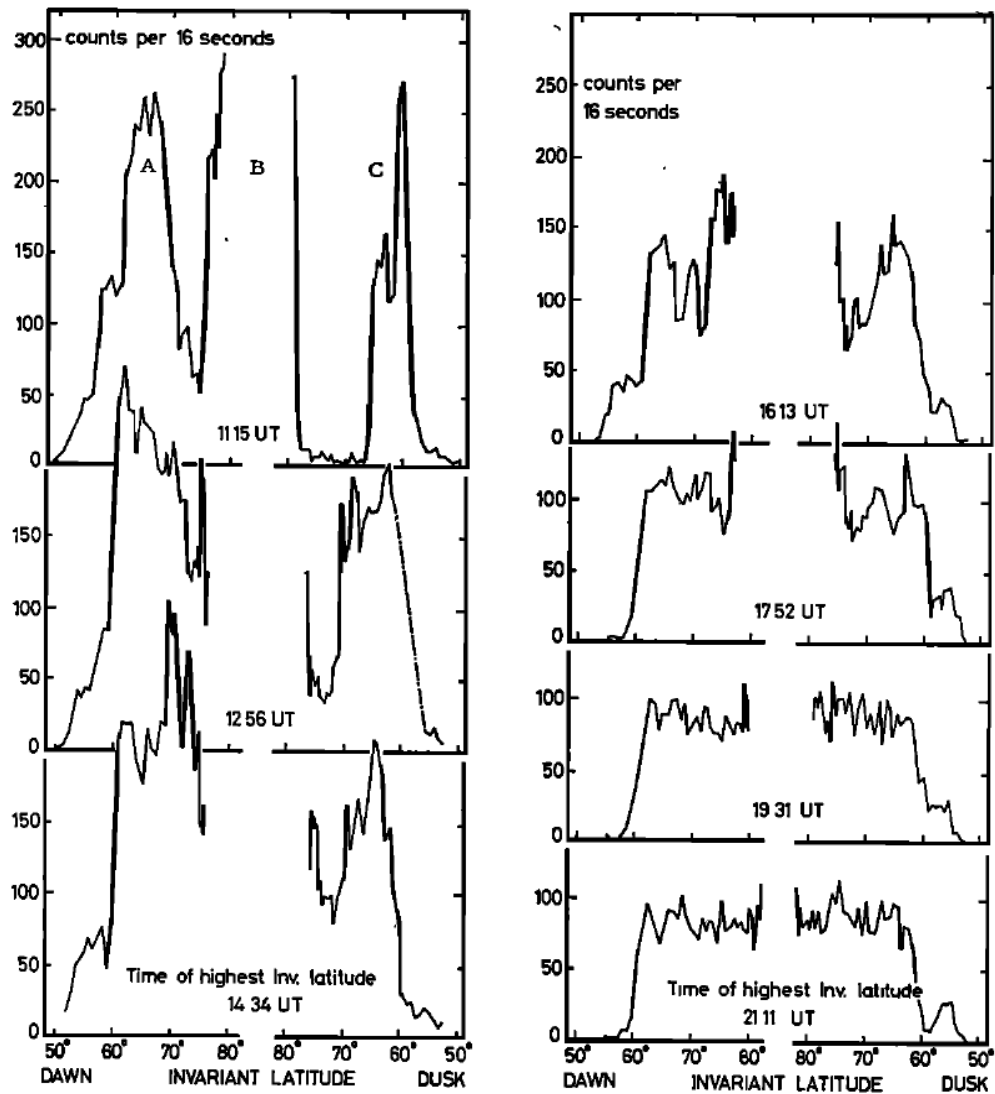

Northern polar-cap observations of the time variation of the intensity structure of 90- to 350-Mev protons made on November 18, 1968, from the low-latitude polar-orbiting ESRO 2 satellite. The first seven northern polar-cap passes after the flare are shown; these passes were made at approximately 100-min intervals. The spacecraft was approximately following the dawn-dusk meridian at this time.



**Experiment S-28 High energy protons**

Durney, Quenby, Morfill, J. Geophys. Res., 77, 3345-3360, 1 July 1972

ESRO-2's polar orbit allowed the observation of how energetic protons from the Sun penetrated the Earth's magnetic dipole field during solar storms.

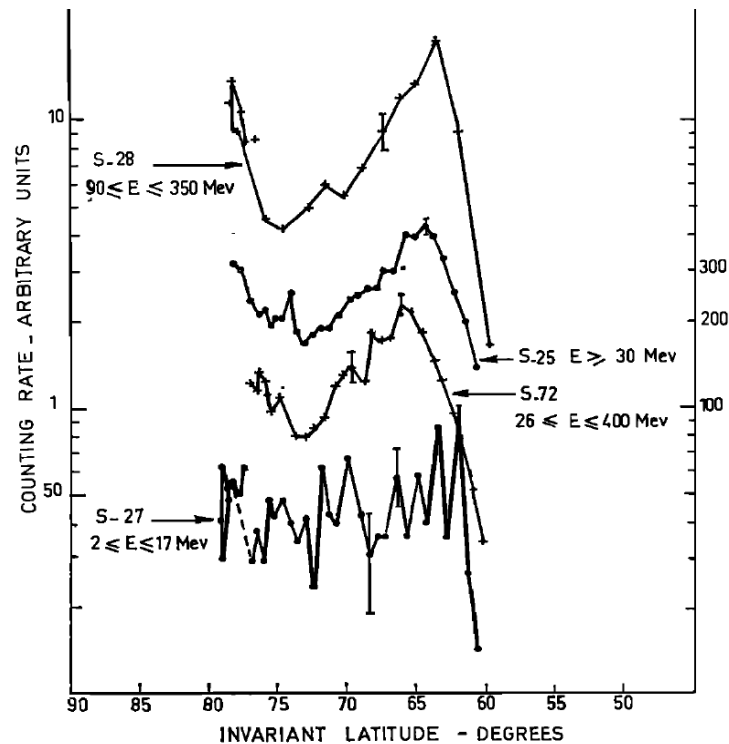

**Penetration of Low-Energy Solar Protons to Low Geomagnetic Latitudes**

A. BEWICK, G. P. HASKELL, AND R. J. HYNDS

*Department of Physics, Imperial College of Science and Technology  
London, England*



Wedding of Arthur and Pat Bewick in 1968. Arthur was responsible for Experiment S25, the Geiger-Muller counter package. He and Pat met in Santa Barbara during the launch campaign of ESRO-2.

# HEOS-1

## HEOS-A

(HIGHLY ECCENTRIC ORBIT SATELLITE)

A EUROPEAN SATELLITE

PRODUCED FOR  
THE EUROPEAN SPACE RESEARCH ORGANISATION  
BY  
JUNKERS FLUGZEUG- UND MOTORENWERKE GMBH



PRIME CONTRACTOR	JUNKERS FLUGZEUG- UND MOTORENWERKE GMBH, GERMANY
CO-CONTRACTORS	ETUDE TECHNIQUES ET CONSTRUCTIONS AEROSPATIALES, BELGIUM BRITISH AIRCRAFT CORPORATION, GT. BRITAIN SOCIETE NATIONALE D'ETUDE ET DE CONSTRUCTION DE MOTEURS D'AVIATION, FRANCE
TELECOMMUNICATIONS CONTRACTOR	COMPAGNIE FRANCAISE THOMSON-HOUSTON, FRANCE WITH SOCIETE ANONYME DE TELECOMMUNICATION, FRANCE AS SUB-CONTRACTOR
EXPERIMENTERS	MAX PLANCK INSTITUT FUR EXTRATERRESTRICHE PHYSIK, GERMANY IMPERIAL COLLEGE, GT. BRITAIN UNIVERSITY OF BRUSSELS, BELGIUM CENTRE D'ETUDES NUCLEAIRES DE SACLAY, FRANCE UNIVERSITIES OF BARY, ROME AND MILAN, ITALY
BOOSTER SYSTEM MANUFACTURER	MCDONNELL DOUGLAS MISSILE AND SPACE SYSTEMS DIVISION, USA
LAUNCH	BY NASA FROM CAPE KENNEDY

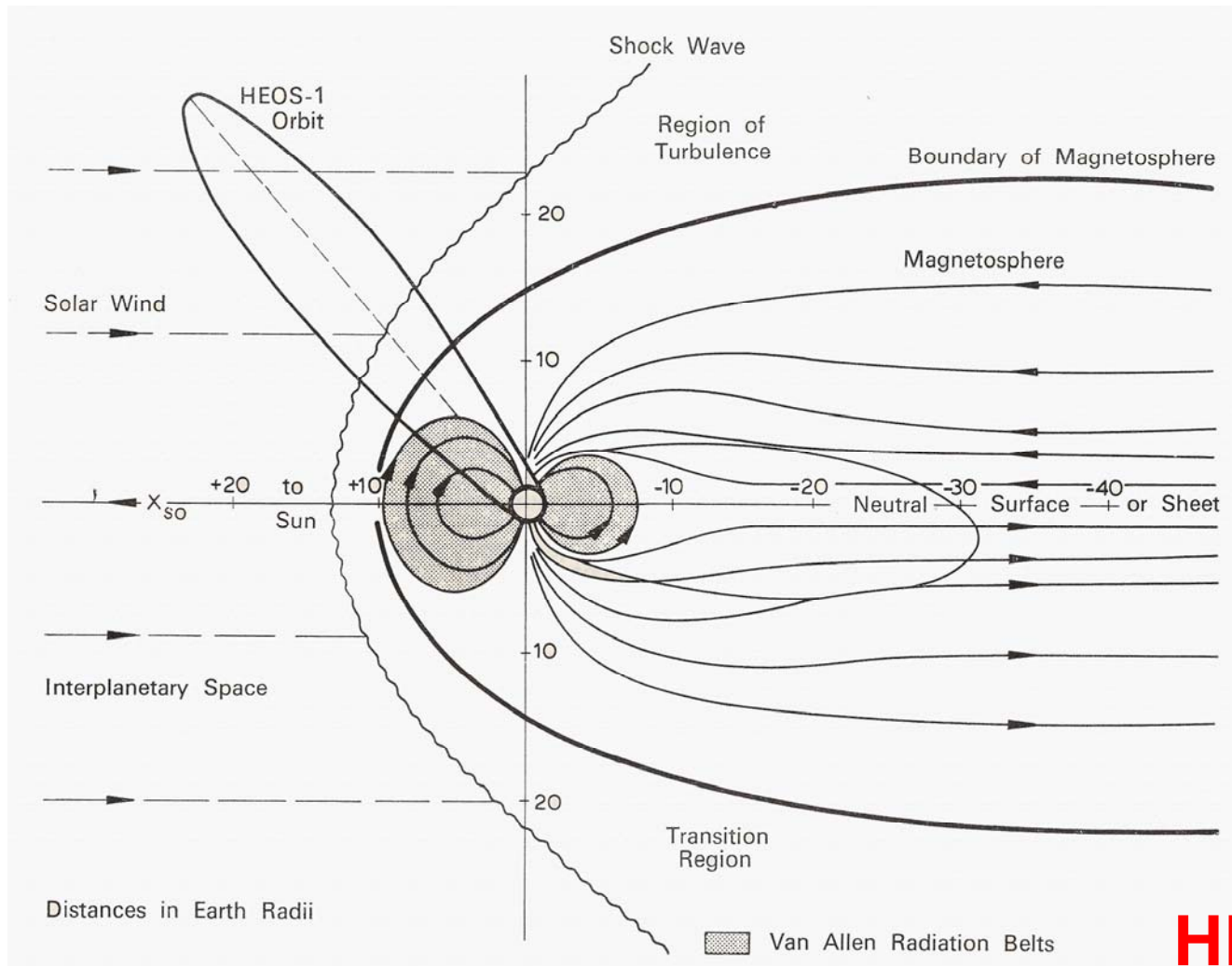

**HEOS-1:**  
**a mission to the boundaries of the magnetosphere and to interplanetary space**

## HEOS-1 PAYLOAD

Experiment	Title	Group	Group leader
S-16	Ion cloud	Max-Planck-Institute for Extraterrestrial Physics, Garching	Prof. Lüst
S-24A	Magnetic fields	Imperial College, London	Prof. Elliot
S-24B	High-energy cosmic ray anisotropy	Imperial College, London	Prof. Elliot
S-24C	Low-energy solar protons	Imperial College, London	Prof. Elliot
S-58/73	Solar wind	Universities of Florence, Rome, Brussels	Professors Bonetti, Pizzella, Coutrez
S-72	Flux and spectrum of cosmic rays	C.E.N. Saclay	Prof. Labeyrie
S-79	Primary cosmic ray electrons	C.E.N. Saclay, University of Milan	Professors Labeyrie & Occhialini- Dilworth



**Photo of the barium  
cloud seen from  
Mount Palomar**

### Response of the magnetic field to the release of the barium cloud

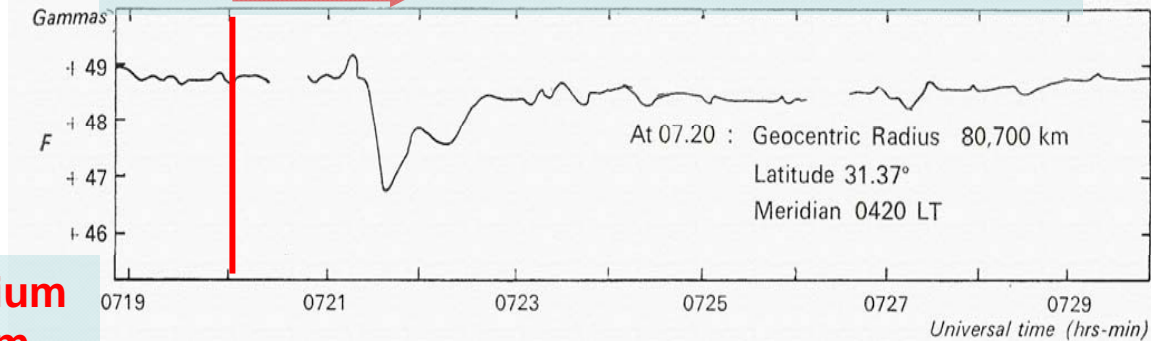

**Andre Balogh, S-24C  
experimenter with  
colleagues from ESRO,  
Junkers and ETCA**

**HEOS-A P1  
breadboard/functional  
interface model  
ETCA, Charleroi, Belgium  
1967**

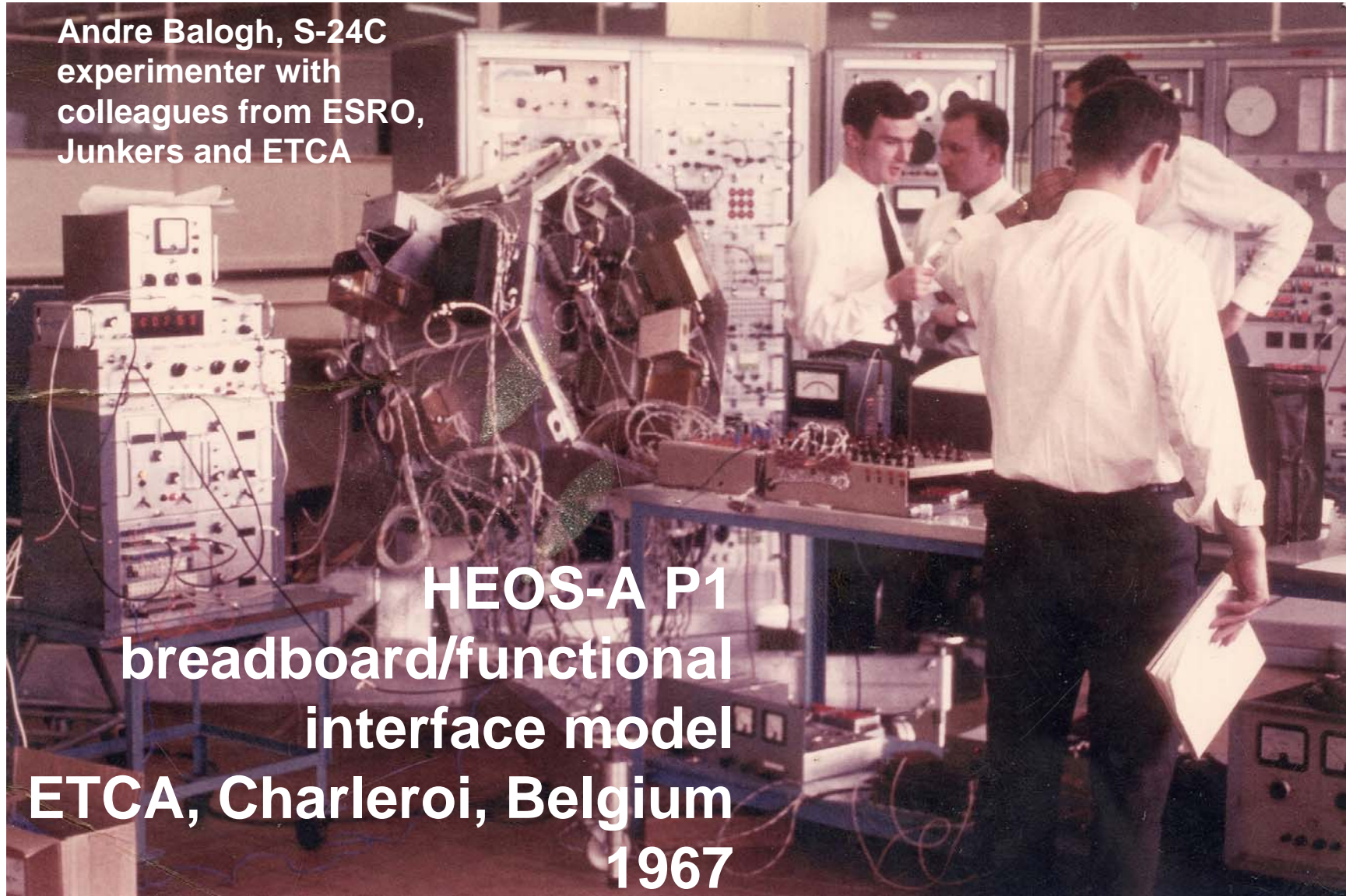

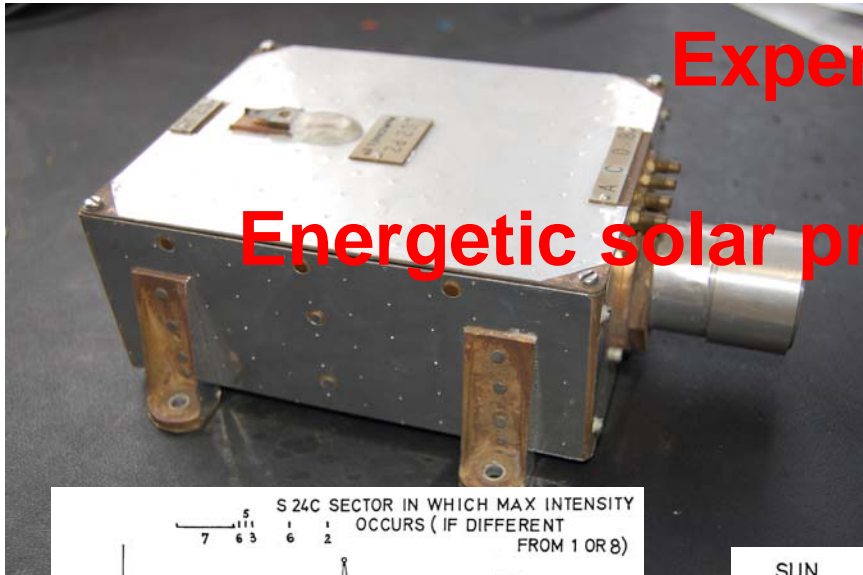

# Experiment S-24C Energetic solar protons

Highly directional propagation of energetic solar protons from a West-limb flare on 25 February 1969, measured by the Instrument S24C on board HEOS-1. These and such results have led to investigations of contradictions between propagation theory and measurements.

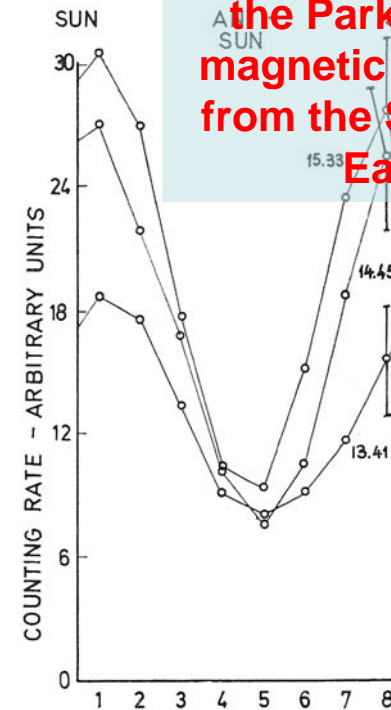
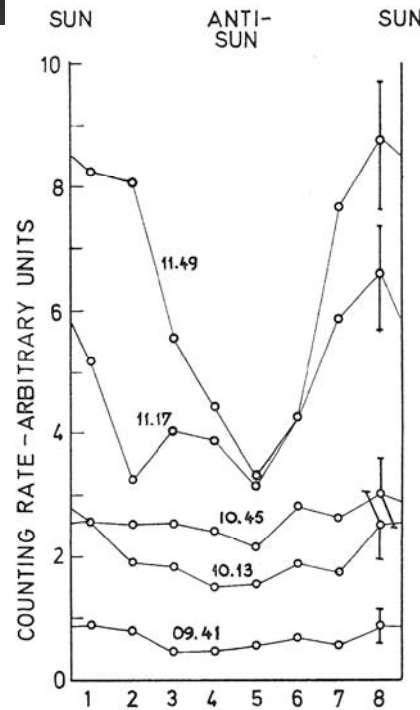
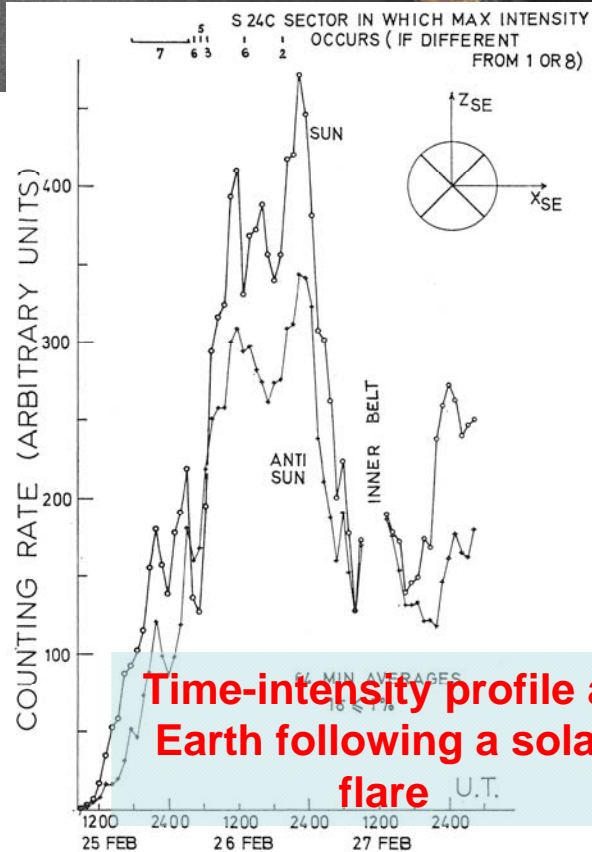

Flux directionality: particles travel along the Parker spiral magnetic field lines from the Sun to the Earth

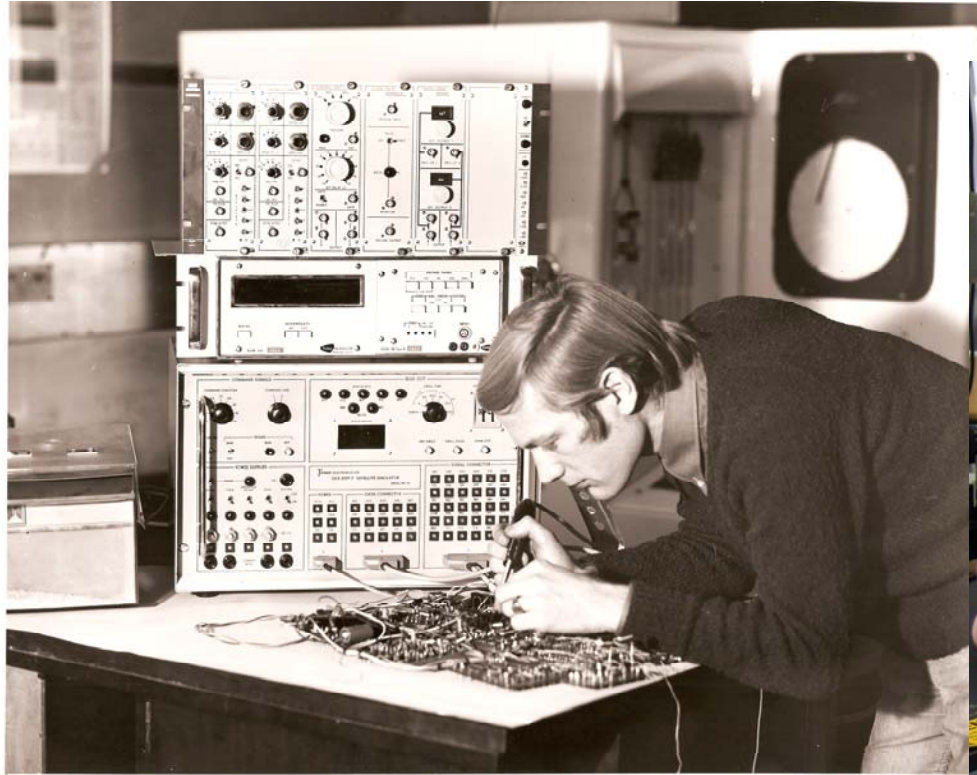

## Space instrumentation in the 1960s and now

Trevor Beek, Imperial College London,  
building instruments and designing  
power supply units since the 1960s

Counting rates

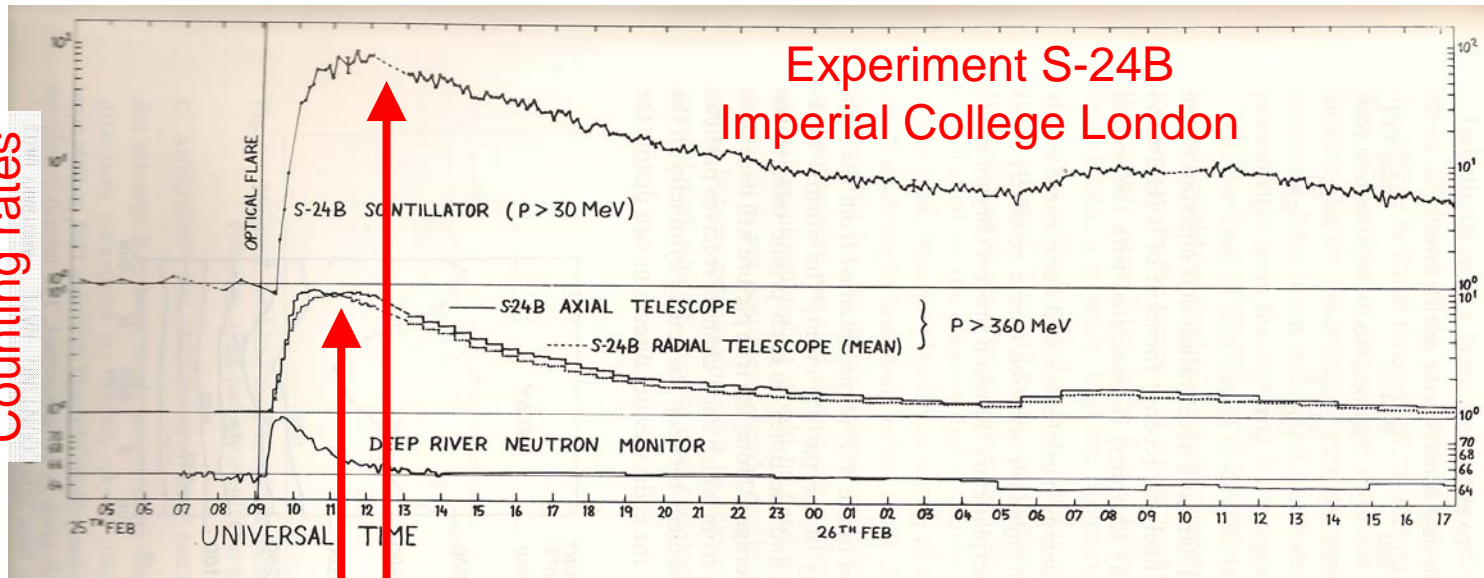

High energy protons observed by HEOS-1 following the large solar flare on 25 February

Dr Andrew Engel, S-24B experimenter inspecting HEOS-A P2 following vibration tests at ESTEC.

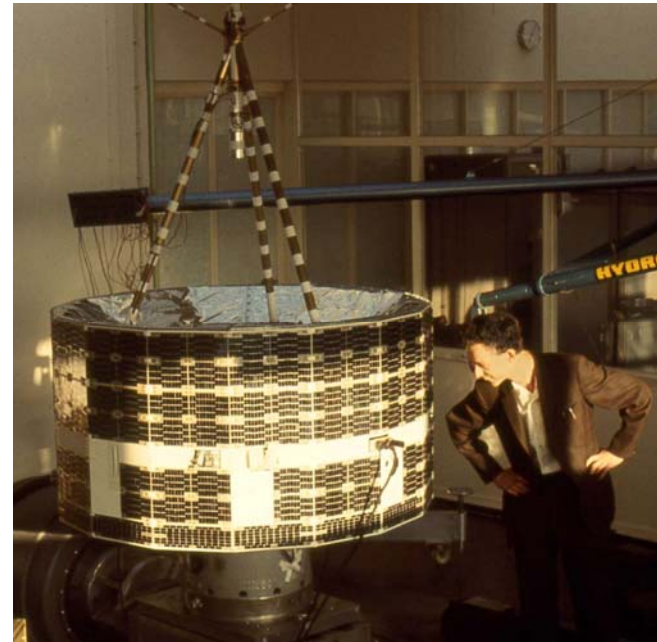

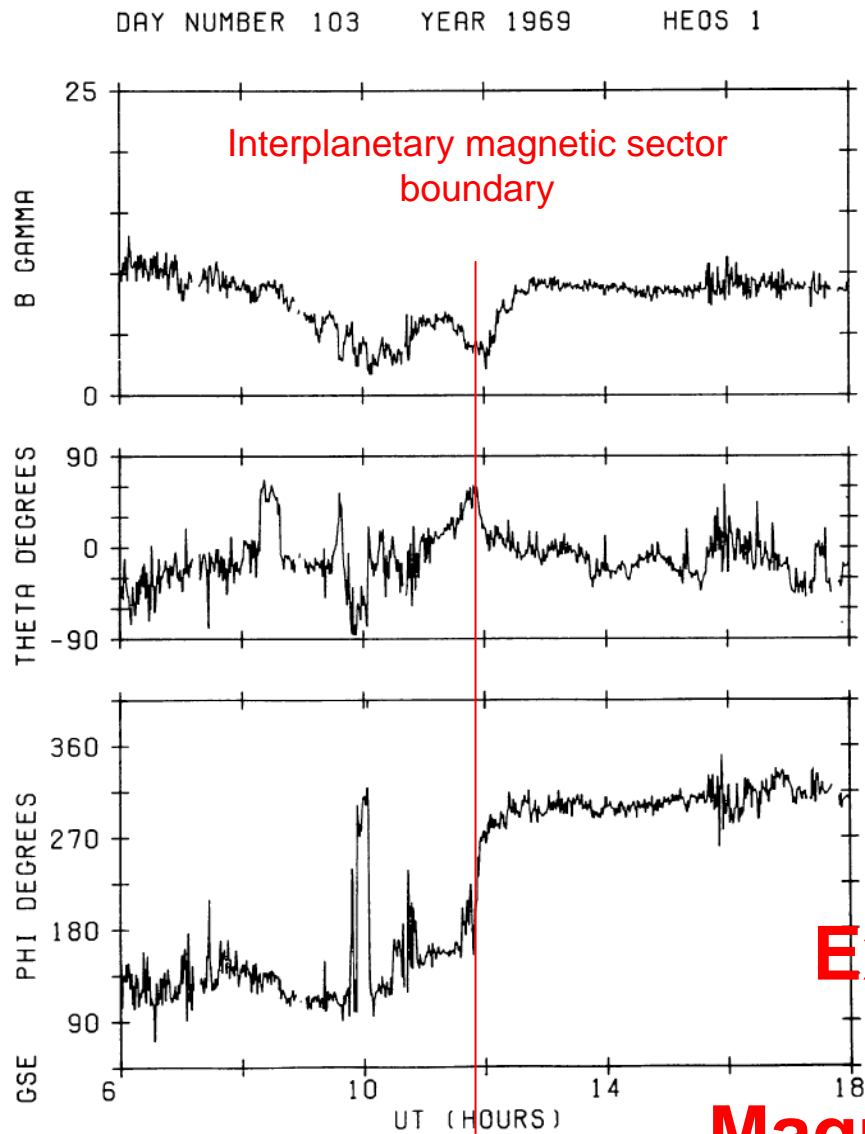

Crossing the interplanetary extension of the Sun's magnetic equator: a sector boundary crossing measured by the S24A instrument on HEOS-1. The large scale structure of the Sun's extended magnetic field in the heliosphere remains a topical research field – recently contributed to by Ulysses.

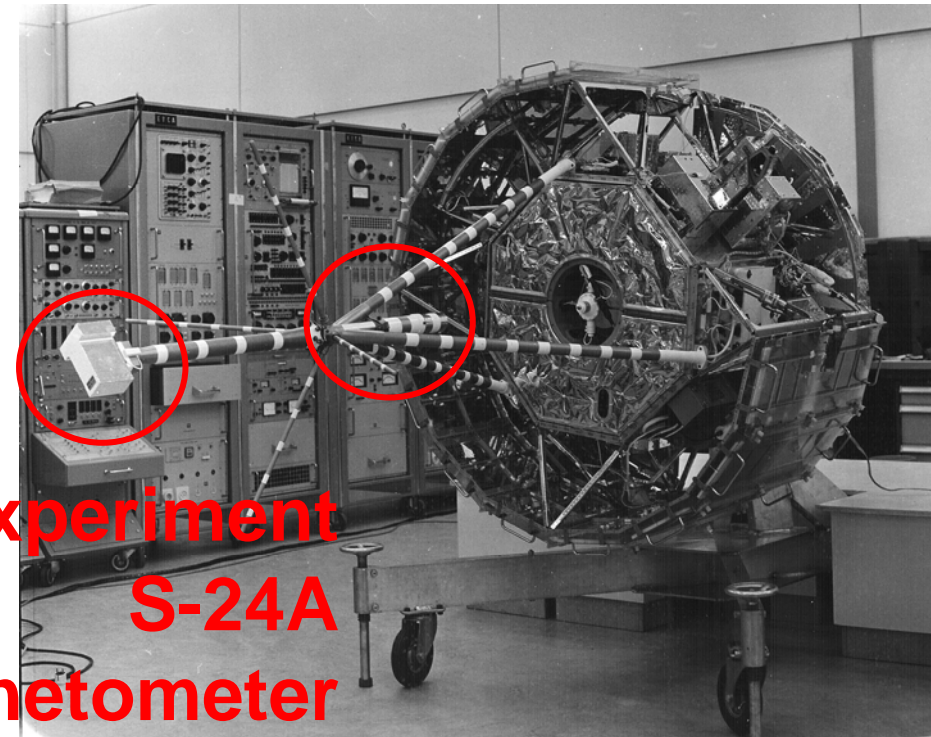

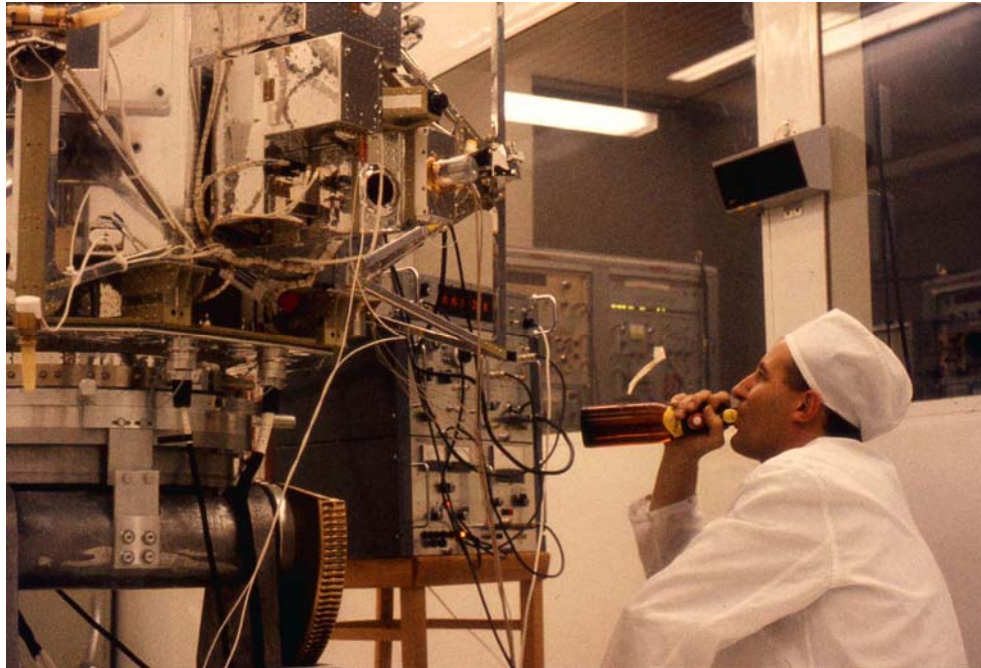

Dr Peter Hedgecock, S-24A experimenter, monitoring experiment check out of HEOS-1 at ESTEC.

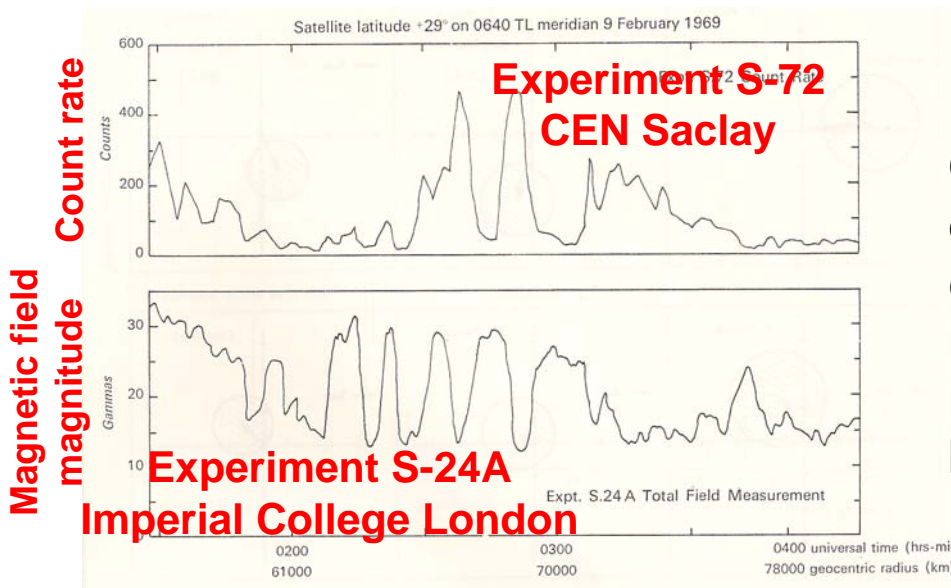

Observations of anti-correlated oscillations in the intensity of high energy particles and the magnitude of the magnetic field near the magnetosphere's boundary

# After-thoughts

- ESRO's first satellites enabled European scientists access to space and to develop a scientific space instrumentation capability
- The first ESRO satellites explored the Earth's space environment and its response to solar events (now called space weather)
- The contribution of ESRO's first satellites fitted well the more develop efforts by NASA
- As has been the case since then, the careful selection of what to do, what instruments to fly and in what orbit by ESRO (and ESA) yielded a proportionally high level of scientific return to European science
- The community that has grown up around ESRO-2, ESRO-1 and HEOS-1 remains active throughout Europe led by the THIRD generation of scientists